

## Two wire universal transmitter programmable by PC

## DAT 1015

### FEATURES

- Configurable input for RTD, mV, Tc, Resistance and Potentiometer
- 4 ÷ 20 mA configurable output on current loop with damping function
- Configurable by Personal Computer by cable CVPROG
- High accuracy
- On-field reconfigurable
- EMC compliant – CE and UKCA mark
- DIN B in-head mounting with option for DIN rail in compliance with EN 50022 (DIN RAIL Option)



### GENERAL DESCRIPTION

The transmitter DAT 1015 is able to execute many functions such as : measure and linearisation of the temperature characteristic of RTDs sensors, conversion of a linear resistance variation, conversion of a voltage signal even coming from a potentiometer connected on its input. Moreover the DAT 1015 is able to measure and linearise the standard thermocouples with internal cold junction compensation. The measured values are converted in a 4+20 mA current signal . The device guarantees high accuracy and performances stability both in time and in temperature.

The programming of the device is made by a Personal Computer using the software DATAPRO and the cable CVPROG, both developed and provided by DATEXEL.

By DATAPRO, that runs under the operative system "Windows™", it is possible to configure the transmitter to interface it with the most used sensors .

In case of sensors with a no-standard output characteristic, it is possible to execute, via software, a "Custom" linearisation (per step) to obtain an output linearised signal .

For Resistance and RTDs sensors it is possible to program the cable compensation with 3 or 4 wires; for Thermocouples it is possible to program the Cold Junction Compensation ( CJC ) as internal or external.

It is possible to set the minimum and maximum values of input and output ranges in any point of the scale, keeping the minimum span shown in the table below.

On the device is provided the function "Damping" that allows the user to set a programmable filter up to 30 seconds to reduce eventual sudden variations of the input signal.

It is housed in a self-extinguish plastic enclosure for DIN B in-head mounting. By proper kit it is possible to mount the device on DIN rail also.

### USER INSTRUCTIONS

The input connections must be made as shown in the sections "Output/Power supply connections" and "Input connections".

To configure, calibrate and install the transmitter refer to sections "Configuration DAT1015" and "Installation Instructions".

### TECHNICAL SPECIFICATIONS (Typical at 25 °C and in nominal conditions)

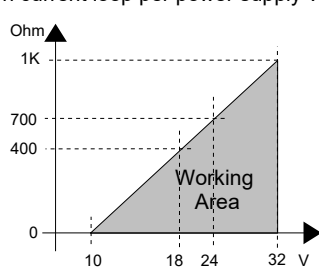
INPUT				OUTPUT				GENERAL SPECIFICATIONS	
Input type	Min	Max	Min Span	Output type	Min	Max	Min Span		
<b>TC(*) CJC int./ext.</b>				Direct current	4 mA	20 mA	4 mA	Power supply voltage	10 .. 32 Vdc
J	-200°C	1200°C	100 °C	Reverse current	20 mA	4 mA	4 mA	Reverse polarity protection	60 Vdc max
K	-200°C	1370°C	100 °C	<b>Output calibration</b>				<b>ENVIRONMENTAL CONDITIONS</b>	
S	-50°C	1760°C	400 °C					Current	± 7 uA
R	-50°C	1760°C	400 °C	<b>Thermal drift (1)</b>				Storage temperature	-40°C .. +85°C
B	400°C	1820°C	400 °C					Full scale	± 0.01% / °C
E	-200°C	1000°C	100 °C	CJC	± 0.01% / °C			Maximum Altitude	2000 m slm
T	-200°C	400°C	100 °C	<b>Burn-out values</b>				Installation	Indoor
N	-200°C	1300°C	100 °C					Max. output value	about 20.5 mA
<b>Voltage</b>				Min. output value	about 3.8 mA		Pollution Degree	2	
mV	-100 mV	+700 mV	2 mV	Max. fault value	about 21.6 mA		<b>MECHANICAL SPECIFICATIONS</b>		
<b>RTD(*) 2,3,4 wires</b>				Min. fault value	about 3.5 mA		Material	PC + ABS V0	
Pt100	-200°C	850°C	50°C	<b>Damping time constant</b>				Mounting	DIN B in-head
Pt1000	-200°C	200°C	50°C					Selectable	from 0.3 to 30 s.
Ni100	-60°C	180°C	50°C	Value 0:	function not active.		AWG	16	
Ni1000	-60°C	150°C	50°C	<b>Response time (10÷ 90%)</b>				Weight	about 50 g.
<b>Potentiometer</b>								about 400 ms	
(nominal value)	0 Ω	200 Ω	10%	<b>Load characteristic - Rload</b> (maximum load value on current loop per power supply value)				IP Code	Enclosure: IP40
	200 Ω	500 Ω	10%						
	0.5 KΩ	50 KΩ	10%						
<b>RES. 2,3,4 wires</b>									
Low	0 Ω	300 Ω	10 Ω						
High	0 Ω	2000 Ω	200 Ω						
<b>Input calibration (1)</b>									
RTD	the higher of ±0.1% f.s. & ±0.2°C								
Res. Low	the higher of ±0.1% f.s. & ±0.15 Ω								
Res. High	the higher of ±0.2% f.s. & ±1 Ω								
mV, Tc	the higher of ±0.1% f.s. & ±10 uV								
<b>Input Impedance</b>									
mV,Tc	≥= 10 MΩ								
<b>Linearity (1)</b>									
RTD	± 0.1 % f.s.								
Tc	± 0.2 % f.s.								
<b>Line resistance influence (1)</b>									
mV,Tc	≤=0.8 uV/Ohm								
RTD 3 wires	0.05%/Ω (50 Ω max balanced)								
RTD 4 wires	0.005%/Ω (100 Ω max balanced)								
<b>RTD excitation current</b>									
Typical	0.350 mA								
<b>CJC comp.</b>	± 1°C								

(1) referred to input Span (difference between max. and min. values)

(\*) For the temperature sensors it is possible to set the measurement also in °F

## CONFIGURATION DAT 1015

**Notice: before to execute the next operations, check that the drivers of the cable CVPROG in use have been previously installed in the Personal Computer.**

- 1) Remove the protection plastic cap.
- 2) Connect the two plugs of cable CVPROG to the Personal Computer (USB plug) and to the device (uUSB plug).
- 3) Run the software DATAPRO. Set the COM port assigned to the CVPROG cable by the Operative System.
- 4) Set the parameters of configuration.
- 5) Program the device.

## CONFIGURATION DAT1015 BY CVPROG CABLE



**Notice, during this operation don't power on the device.**

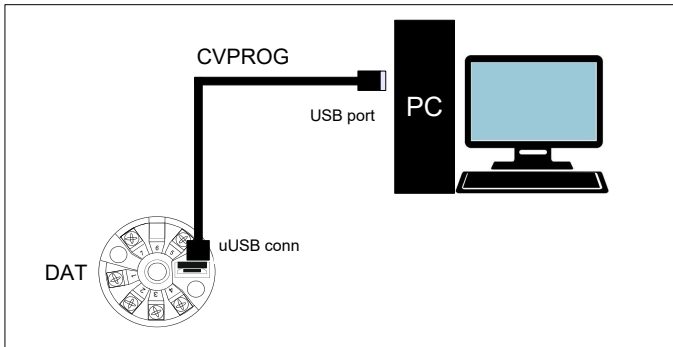

### DIN B in-head mounting

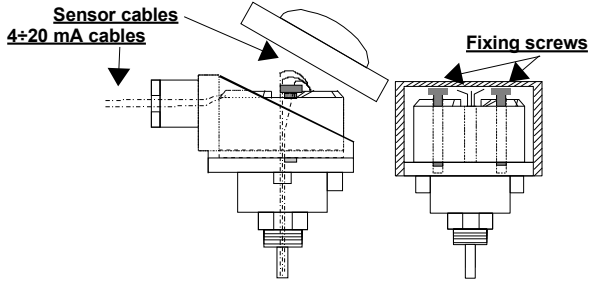

### DIN rail mounting (DIN RAIL Option)

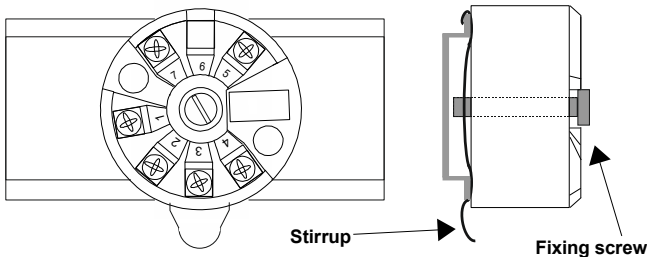

## INSTALLATION INSTRUCTIONS

The device DAT 1015 is suitable for direct DIN B in-head mounting. The transmitter must be fixed inside the probe by the proper kit.

By apposite stirrup, provided on request, it is possible to mount the device on DIN rail in compliance with EN-50022. It is necessary to install the device in a place without vibrations; avoid to routing conductors near power signal cables.

## DAT1015 WIRING

### INPUT CONNECTIONS

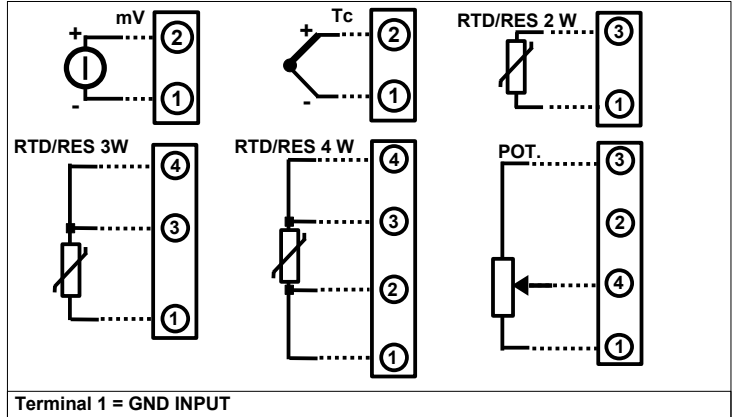

### OUTPUT/POWER SUPPLY CONNECTIONS

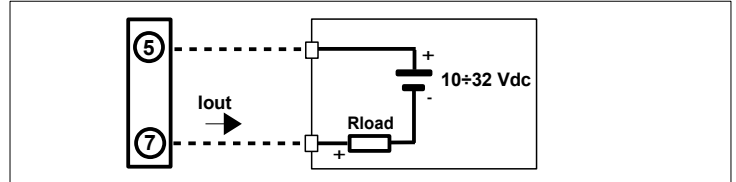

## DAMPING FUNCTION

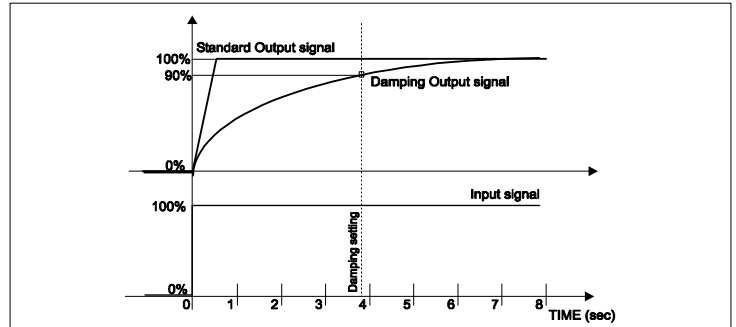

Example with damping = 3.9 seconds

## MECHANICAL DIMENSIONS (mm)

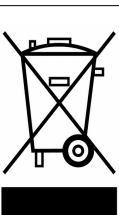
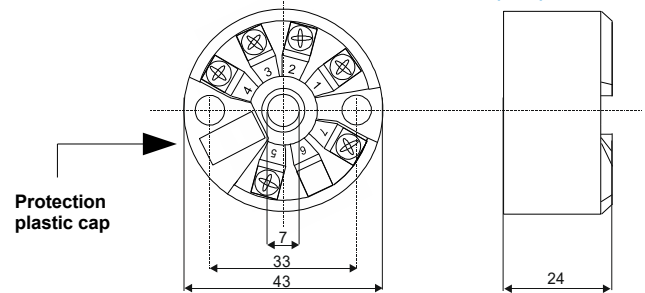

The symbol reported on the product indicates that the product itself must not be considered as a domestic waste. It must be brought to the authorized recycle plant for the recycling of electrical and electronic waste. For more information contact the proper office in the user's city, the service for the waste treatment or the supplier from which the product has been purchased.

## HOW TO ORDER

The DAT1015 is provided as requested on the Customer's order. Refer to the section "Technical specification" to determine input and output ranges. The mounting kit for DIN rail is provided **only on request** with code **DIN RAIL**. In case of the configuration is not specified, the parameters must be set by the user.

### ORDER CODE EXAMPLE:

DAT 1015 / Pt100 / 3 wires / 0 ÷ 200 °C / S.L. / 4 ÷ 20 mA / Burn-out up	
Input type	High or low Out of scale
Sensor options : RTD/RES:2,3,4 wires	Output range
Input range	(*) Linearisation options: S.L.: standard linearisation. N.L.: no linearisation. C.L.: linearisation by step (Custom): specify input curve