

Isolated two wire universal transmitter programmable by PC

DAT 1066

FEATURES

- Configurable input for RTD, mV, Tc, Resistance and Potentiometer
- 1500 Vac Galvanic isolation
- 4 ÷ 20 mA configurable output on current loop with damping function
- Configurable by Personal Computer by cable CVPROG
- High accuracy
- On-field reconfigurable
- EMC compliant – CE and UKCA mark
- DIN B in-head mounting with option for DIN rail in compliance with EN 50022 (DIN RAIL Option)



GENERAL DESCRIPTION

The isolated transmitter DAT 1066 is able to execute many functions such as : measure and linearisation of the temperature characteristic of RTDs sensors, conversion of a linear resistance variation, conversion of a voltage signal even coming from a potentiometer connected on its input. Moreover the DAT 1066 is able to measure and linearise the standard thermocouples with internal cold junction compensation. The measured values are converted in a 4÷20 mA current signal . The device guarantees high accuracy and performance stability both in time and in temperature.

The programming of the device is made by a Personal Computer using the software DATAPRO and the cable CVPROG, both developed and provided by DATEXEL. By DATAPRO , that runs under the operative system "Windows™", it is possible to configure the transmitter to interface it with the most used sensors .In case of sensors with a no-standard output characteristic, it is possible to execute, via software, a "Custom" linearisation (per step) to obtain an output linearised signal .

For Resistance and RTDs sensors it is possible to program the cable compensation with 3 or 4 wires; for Thermocouples it is possible to program the Cold Junction Compensation (CJC) as internal or external.

It is possible to set the minimum and maximum values of input and output ranges in any point of the scale, keeping the minimum span shown in the table below. Moreover it is available the option of alarm for signal interruption (burn-out) that allows to set the output value as high or low out of scale .

On the device is provided the function "Damping" that allows the user to set a programmable filter up to 30 seconds to reduce eventual sudden variations of the input signal.

The 1500 Vac isolation between input and power supply/output eliminates the effects of all ground loops eventually existing and allows the use of the transmitter in heavy environmental conditions found in industrial applications.

It is housed in a self-extinguish plastic enclosure for DIN B in-head mounting. By proper kit it is possible to mount the device on DIN rail also.

USER INSTRUCTIONS

The input connections must be made as shown in the sections "Output/Power supply connections" and "Input connections".

To configure, calibrate and install the transmitter refer to sections "Configuration DAT1066" and "Installation Instructions".

TECHNICAL SPECIFICATIONS (Typical at 25 °C and in nominal conditions)

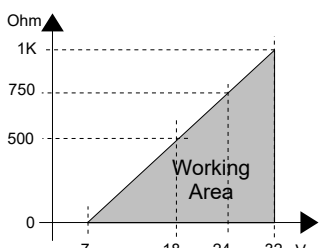
INPUT				OUTPUT				GENERAL SPECIFICATIONS					
Input type	Min	Max	Min Span	Output type	Min	Max	Min Span						
TC(*) CJC int./ext.				Direct current	4 mA	20 mA	4 mA	Power supply voltage	7 .. 32 Vdc				
J	-200°C	1200°C	100 °C	Reverse current	20 mA	4 mA	4 mA	Reverse polarity protection	60 Vdc max				
K	-200°C	1370°C	100 °C	Output calibration				ISOLATION					
S	-50°C	1760°C	400 °C					Input – Output/Pow.supply	1500 Vac, 50 Hz,1 min.				
R	-50°C	1760°C	400 °C	Current	± 7 uA			ENVIRONMENTAL CONDITIONS					
B	400°C	1820°C	400 °C	Thermal drift (1)				Operative temperature	-40°C .. +85°C				
E	-200°C	1000°C	100 °C					Full scale	± 0.01% / °C			Storage temperature	-40°C .. +85°C
T	-200°C	400°C	100 °C	CJC	± 0.01% / °C			Humidity (not condensing)	0 .. 90 %				
N	-200°C	1300°C	100 °C	Burn-out values				Maximum Altitude	2000 m slm				
Voltage								Max. output value	about 20.5 mA			Installation	Indoor
mV	-100 mV	+700 mV	2 mV					Min. output value	about 3.8 mA			Category of Installation	II
RTD(*) 2,3,4 wires								Max. fault value	about 21.6 mA			Pollution Degree	2
Pt100	-200°C	850°C	50°C	Min. fault value	about 3.5 mA			MECHANICAL SPECIFICATIONS					
Pt1000	-200°C	200°C	50°C	Damping time constant				Material	PC + ABS V0				
Ni100	-60°C	180°C	50°C					Selectable	from 0.3 to 30 s.			Mounting	DIN B in-head
Ni1000	-60°C	150°C	50°C	Value 0:	function not active.			Wiring	Wire section max 1.5 mm ² AWG 16				
Potentiometer				Response time (10÷ 90%)				Weight	about 50 g.				
(nominal value)	0 Ω	200 Ω	10%					about 400 ms	Dimensions			∅ = 43 mm ; H = 24 mm	
	200 Ω	500 Ω	10%	Load characteristic - Rload (maximum load value on current loop per power supply value)				IP Code	Enclosure: IP40 Terminals : IP10				
	0.5 KΩ	50 KΩ	10%										
RES. 2,3,4 wires													
Low	0 Ω	300 Ω	10 Ω										
High	0 Ω	2000 Ω	200 Ω										
Input calibration (1)													
RTD	the higher of ±0.1% f.s. & ±0.2°C												
Res. Low	the higher of ±0.1% f.s. & ±0.15 Ω												
Res. High	the higher of ±0.2% f.s. & ±1 Ω												
mV, Tc	the higher of ±0.1% f.s. & ±10 uV												
Input Impedance													
mV,Tc	≥ 10 MΩ												
Linearity (1)													
RTD	± 0.1 % f.s.												
Tc	± 0.2 % f.s.												
Line resistance influence (1)													
mV,Tc	≤ 0.8 uV/Ohm												
RTD 3 wires	0.05%/Ω (50 Ω max balanced)												
RTD 4 wires	0.005%/Ω (100 Ω max balanced)												
RTD excitation current													
Typical	0.350 mA												
CJC comp.	± 1°C												

(1) referred to input Span (difference between max. and min. values)

(*) For the temperature sensors it is possible to set the measurement also in °F

CERTIFICATIONS

EMC (for the Industrial Environments)

Immunity EN 61000-6-2

Emission EN 61000-6-4

UKCA (ref S.I. 2016 N°1091)

Immunity BS EN 61000-6-2

Emission BS EN 61000-6-4

CONFIGURATION DAT 1066

Notice: before to execute the next operations, check that the drivers of the cable CVPROG in use have been previously installed in the Personal Computer.

- 1) Remove the protection plastic cap.
- 2) Connect the two plugs of cable CVPROG to the Personal Computer (USB plug) and to the device (uUSB plug).
- 3) Run the software DATAPRO. Set the COM port assigned to the CVPROG cable by the Operative System.
- 4) Set the parameters of configuration.
- 5) Program the device.

- CALIBRATION CONTROL

With software running and device powered:

- 1) Connect on the input a calibrator setted with minimum and maximum values referred to the electric signal or to the temperature sensor to measure.
 - 2) Set the calibrator at the minimum value.
 - 3) Verify that the device provides on output the minimum setted value.
 - 4) Set the calibrator at the maximum value.
 - 5) Verify that the device provides on output the maximum setted value.
 - 6) In case of regulation of value obtained in the step 3 and 5, use the ZERO and SPAN regulators of software.
- The variation introduced from these regulators must be calculated as percentage of the input range.
- 7) Program the device with the new parameters.

CONFIGURATION DAT1061 BY CVPROG CABLE

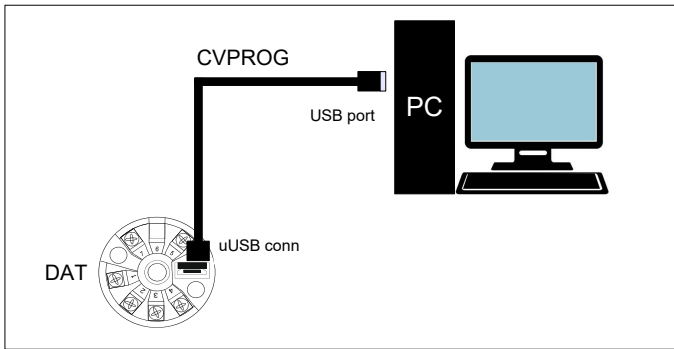

DIN B in-head mounting

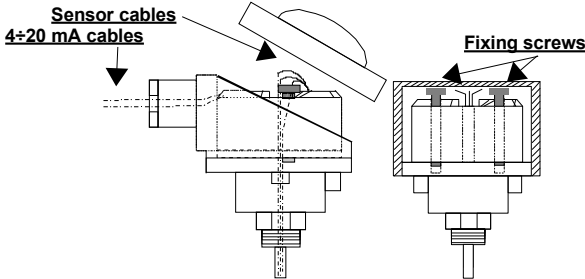

DIN rail mounting (DIN RAIL Option)

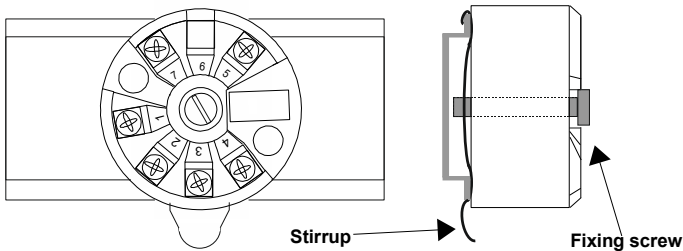

ISOLATION STRUCTURE

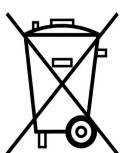

The symbol reported on the product indicates that the product itself must not be considered as a domestic waste. It must be brought to the authorized recycle plant for the recycling of electrical and electronic waste. For more information contact the proper office in the user's city, the service for the waste treatment or the supplier from which the product has been purchased.

INSTALLATION INSTRUCTIONS

The device DAT1066 is suitable for direct DIN B in-head mounting. The transmitter must be fixed inside the probe by the proper kit. By apposite stirrup, provided on request, it is possible to mount the device on DIN rail in compliance with EN-50022. It is necessary to install the device in a place without vibrations; avoid to routing conductors near power signal cables.

DAT1066 WIRING

INPUT CONNECTIONS

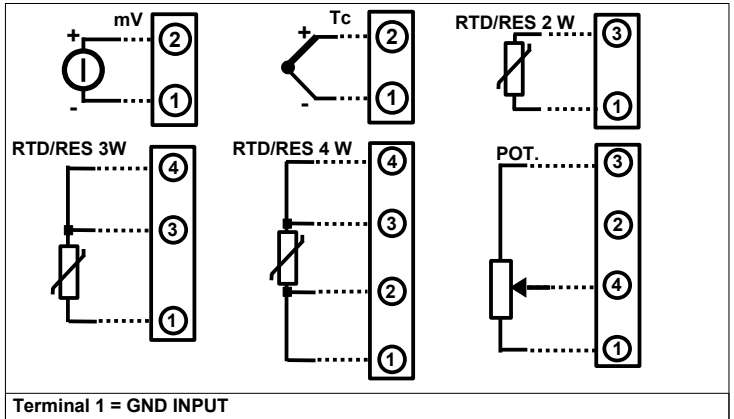

OUTPUT/POWER SUPPLY CONNECTIONS

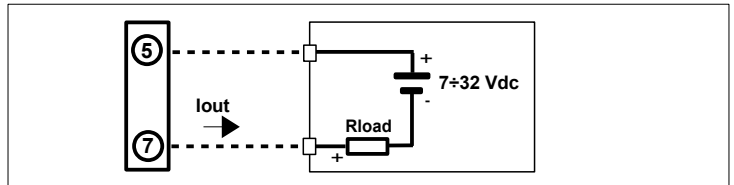

DAMPING FUNCTION

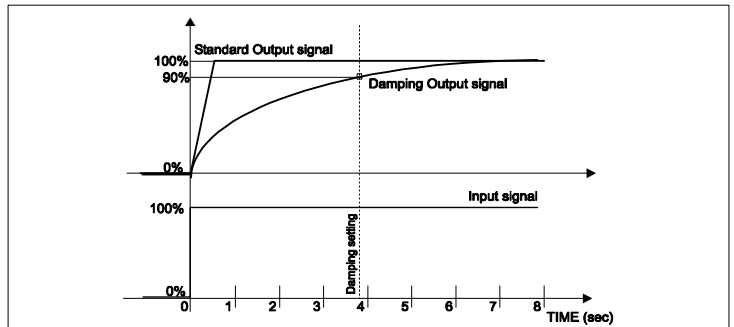

Example with damping = 3.9 seconds

MECHANICAL DIMENSIONS (mm)

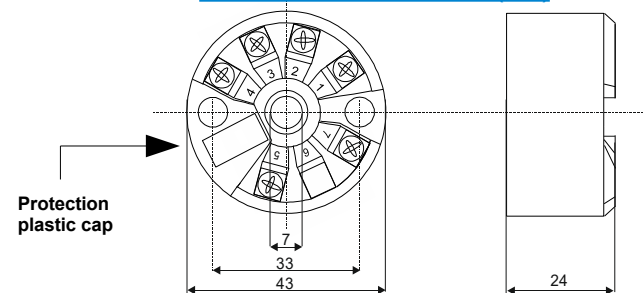

HOW TO ORDER

The DAT1066 is provided as requested on the Customer's order. Refer to the section "Technical specification" to determine input and output ranges. The mounting kit for DIN rail is provided **only on request** with code DIN RAIL. In case of the configuration is not specified, the parameters must be set by the user.

ORDER CODE EXAMPLE:

