

## Isolated converter with output 0÷10 V programmable by PC

# DAT 1135

### FEATURES

- Configurable input for RTD, mV, Tc, Resistance and Potentiometer
- 1500 Vac Galvanic isolation
- Voltage output configurable from 0 up to 10 Vdc with damping function
- Configurable by Personal Computer by cable CVPROG
- High accuracy
- On-field reconfigurable
- EMC compliant – CE and UKCA mark
- DIN B in-head mounting with option for DIN rail in compliance with EN 50022 (DIN RAIL Option)



### GENERAL DESCRIPTION

The isolated converter DAT1135 is able to execute many functions such as: measure and linearisation of the temperature characteristic of RTDs sensors, conversion of a linear resistance variation, conversion of a voltage signal even coming from a potentiometer connected on its input. The DAT1135 is able to measure and linearise the standard thermocouples with internal cold junction compensation. The measured values are converted in a 0÷10 V signal. The device guarantees high accuracy and performance stability both in time and in temperature.

The programming of the DAT1135 is made by a Personal Computer using the software DATAPRO and the cable CVPROG, both developed and provided by DATEXEL. By DATAPRO, that runs under the operative system "Windows™", it is possible to configure the transmitter to interface it with the most used sensors.

For Resistance and RTDs sensors it is possible to program the cable compensation with 3 or 4 wires; for Thermocouples it is possible to program the Cold Junction Compensation (CJC) as internal or external.

It is possible to set the minimum and maximum values of input and output ranges in any point of the scale, keeping the minimum span shown in the table below.

It is available the option of alarm for signal interruption (burn-out) that allows to set the output value as high or low out of scale.

On the device is provided a function that allows the user to set a programmable filter up to 30 seconds to reduce eventual sudden variations of the input signal.

The 1500 Vac isolation between input and power supply/output eliminates the effects of all ground loops eventually existing and allows the use of the converter in heavy environmental conditions found in industrial applications.

It is housed in a self-extinguish plastic enclosure for DIN B in-head mounting. By proper kit it is possible to mount the device on DIN rail also.

### USER INSTRUCTIONS

The input connections must be made as shown in the sections "Output/Power supply connections" and "Input connections".

To configure, calibrate and install the transmitter refer to sections "Configuration DAT1135" and "Installation Instructions".

### TECHNICAL SPECIFICATIONS (Typical at 25 °C and in nominal conditions)

INPUT				OUTPUT				GENERAL SPECIFICATIONS	
Input type	Min	Max	Min Span	Output type	Min	Max	Min Span		
<b>TC(*) CJC int./ext.</b>				Direct voltage	0 V	10 V	1 V	Power supply voltage	18 .. 30 Vdc
J	-200°C	1200°C	100 °C	Reverse voltage	10 V	0 V	1 V	Current consumption	10 mA max.
K	-200°C	1300°C	100 °C	<b>Output calibration</b> Voltage ± 5 mV				<b>ISOLATION</b> Input – Output/Pow.supply 1500 Vac, 50 Hz, 1 min.	<b>ENVIRONMENTAL CONDITIONS</b> Operative temperature -40°C .. +85°C Storage temperature -40°C .. +85°C Humidity (not condensing) 0 .. 90 % Maximum Altitude 2000 m slm Installation Indoor Category of Installation II Pollution Degree 2
S	0°C	1750°C	400 °C						
R	0°C	1750°C	400 °C	<b>Thermal drift (1)</b> Full scale ± 0.01% / °C CJC ± 0.01% / °C				<b>MECHANICAL SPECIFICATIONS</b> Material PC + ABS V0 Mounting DIN B in-head Wiring Wire section max 1.5 mm <sup>2</sup> AWG 16 Weight about 50 g. Dimensions Ø = 43 mm ; H = 24 mm IP Code Enclosure: IP40 Terminals : IP10	
B	0°C	1800°C	400 °C						
E	-200°C	1000°C	100 °C	<b>Burn-out values</b> Max. Fault value about 11.1 V Min. Fault value about -0.65 V				<b>CERTIFICATIONS</b> <b>EMC ( for the Industrial Environments )</b> Immunity EN 61000-6-2 Emission EN 61000-6-4 <b>UKCA (ref S.I. 2016 N°1091 )</b> Immunity BS EN 61000-6-2 Emission BS EN 61000-6-4	
T	-200°C	400°C	100 °C						
N	-200°C	1300°C	100 °C	<b>Damping time constant</b> Selectable from 0.2 to 30 s Value 0: function not active.				<b>Response time (10÷ 90%)</b> about 200 ms	
<b>Voltage</b>									
mV	-100mV	+90mV	5 mV	<b>Output Load resistance – Rload</b> Voltage output ≥ 5 KΩ Short-circuit current 26 mA max					
mV	-100mV	+200mV	10 mV						
mV	-100mV	+800mV	20 mV	<b>Output excitation current</b> Typical 0.350 mA <b>CJC comp.</b> ± 1°C					
<b>RTD(*) 2,3,4 wires</b>									
Pt100	-200°C	850°C	50°C	<b>Line resistance influence (1)</b> mV,Tc ≤0.8 uV/Ohm RTD 3 wires 0.05%/Ω (50 Ω max balanced) RTD 4 wires 0.005%/Ω (100 Ω max balanced)					
Pt1000	-200°C	185°C	50°C						
Ni100	-60°C	180°C	50°C	<b>RTD excitation current</b> Typical 0.350 mA <b>CJC comp.</b> ± 1°C					
Ni1000	-60°C	150°C	50°C						
<b>Potentiometer</b> (nominal value)	0 %	100 %	5%	<b>RES. 2,3,4 wires</b> Low 0 Ω 500 Ω 50 Ω High 0 Ω 2000 Ω 500 Ω					
<b>RES. 2,3,4 wires</b>									
Low	0 Ω	500 Ω	50 Ω	<b>Input calibration (1)</b> RTD the higher of ±0.1% f.s. & ±0.2°C Res. Low the higher of ±0.1% f.s. & ±0.15 Ω Res. High the higher of ±0.2% f.s. & ±1 Ω mV, Tc the higher of ±0.1% f.s. & ±10 uV <b>Input Impedance</b> mV,Tc ≥= 10 MΩ <b>Linearity (1)</b> RTD ± 0.1 % f.s. Tc ± 0.2 % f.s.					
High	0 Ω	2000 Ω	500 Ω						
<b>Input calibration (1)</b>				<b>Linearity (1)</b> RTD ± 0.1 % f.s. Tc ± 0.2 % f.s.					
RTD									
Res. Low				<b>Line resistance influence (1)</b> mV,Tc ≤0.8 uV/Ohm RTD 3 wires 0.05%/Ω (50 Ω max balanced) RTD 4 wires 0.005%/Ω (100 Ω max balanced)					
Res. High									
mV, Tc				<b>RTD excitation current</b> Typical 0.350 mA <b>CJC comp.</b> ± 1°C					
<b>Input Impedance</b>									
mV,Tc				<b>RES. 2,3,4 wires</b> Low 0 Ω 500 Ω 50 Ω High 0 Ω 2000 Ω 500 Ω					
<b>Linearity (1)</b>									
RTD				<b>Input calibration (1)</b> RTD the higher of ±0.1% f.s. & ±0.2°C Res. Low the higher of ±0.1% f.s. & ±0.15 Ω Res. High the higher of ±0.2% f.s. & ±1 Ω mV, Tc the higher of ±0.1% f.s. & ±10 uV <b>Input Impedance</b> mV,Tc ≥= 10 MΩ <b>Linearity (1)</b> RTD ± 0.1 % f.s. Tc ± 0.2 % f.s.					
Tc									
<b>Line resistance influence (1)</b>				<b>Line resistance influence (1)</b> mV,Tc ≤0.8 uV/Ohm RTD 3 wires 0.05%/Ω (50 Ω max balanced) RTD 4 wires 0.005%/Ω (100 Ω max balanced)					
mV,Tc									
RTD 3 wires				<b>RTD excitation current</b> Typical 0.350 mA <b>CJC comp.</b> ± 1°C					
RTD 4 wires									
<b>RTD excitation current</b>				<b>RES. 2,3,4 wires</b> Low 0 Ω 500 Ω 50 Ω High 0 Ω 2000 Ω 500 Ω					
Typical									
<b>CJC comp.</b>				<b>Input calibration (1)</b> RTD the higher of ±0.1% f.s. & ±0.2°C Res. Low the higher of ±0.1% f.s. & ±0.15 Ω Res. High the higher of ±0.2% f.s. & ±1 Ω mV, Tc the higher of ±0.1% f.s. & ±10 uV <b>Input Impedance</b> mV,Tc ≥= 10 MΩ <b>Linearity (1)</b> RTD ± 0.1 % f.s. Tc ± 0.2 % f.s.					
± 1°C									

(1) referred to input Span (difference between max. and min. values)

(\*) For the temperature sensors it is possible to set the measurement also in °F

### CONFIGURATION DAT 1135

**Notice: before to execute the next operations, check that the drivers of the cable CVPROG in use have been previously installed in the Personal Computer.**

- 1) Remove the protection plastic cap.
- 2) Connect the two plugs of cable CVPROG to the Personal Computer (USB plug) and to the device (uUSB plug).
- 3) Run the software DATAPRO. Set the COM port assigned to the CVPROG cable by the Operative System.
- 4) Set the parameters of configuration.
- 5) Program the device.

#### - CALIBRATION CONTROL

**With software running and device powered:**

- 1) Connect on the input a calibrator setted with minimum and maximum values referred to the electric signal or to the temperature sensor to measure.
- 2) Set the calibrator at the minimum value.
- 3) Verify that the device provides on output the minimum set value.
- 4) Set the calibrator at the maximum value.
- 5) Verify that the device provides on output the maximum set value.

### CONFIGURATION DAT1135 BY CVPROG CABLE

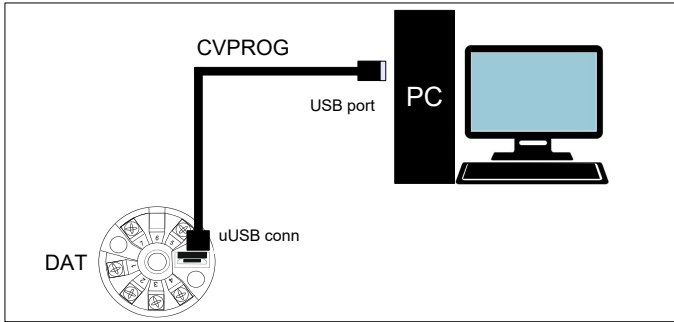

### DAMPING FUNCTION

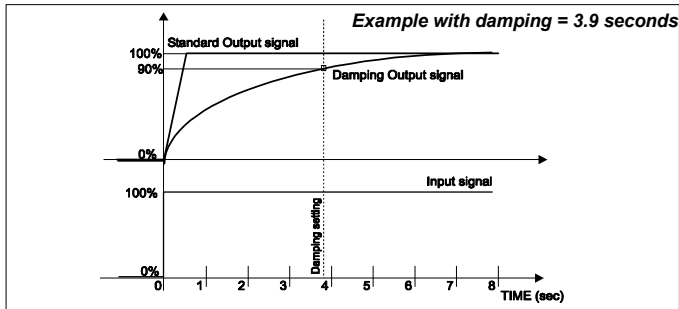

### DIN B in-head mounting

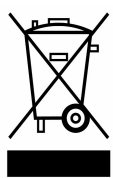
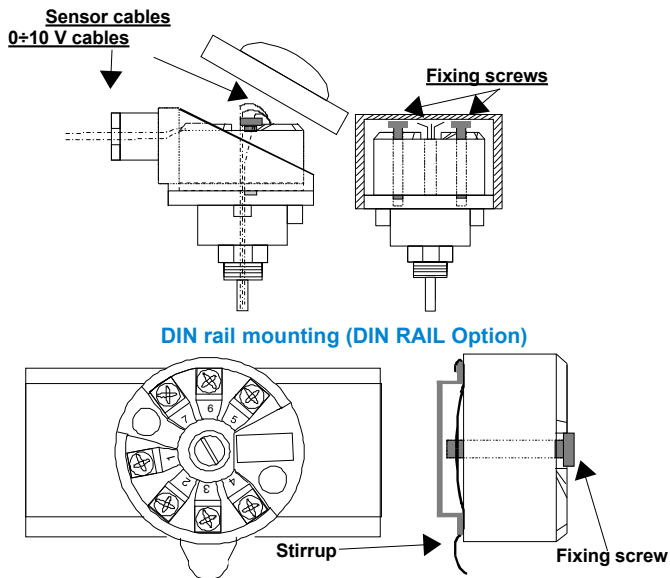

The symbol reported on the product indicates that the product itself must not be considered as a domestic waste. It must be brought to the authorized recycle plant for the recycling of electrical and electronic waste. For more information contact the proper office in the user's city, the service for the waste treatment or the supplier from which the product has been purchased.

### INSTALLATION INSTRUCTIONS

The device DAT1135 is suitable for direct DIN B in-head mounting. The transmitter must be fixed inside the probe by the proper kit. By apposite stirrup, provided on request, it is possible to mount the device on DIN rail in compliance with EN-50022. It is necessary to install the device in a place without vibrations; avoid to routing conductors near power signal cables.

### DAT1135 WIRING

#### INPUT CONNECTIONS

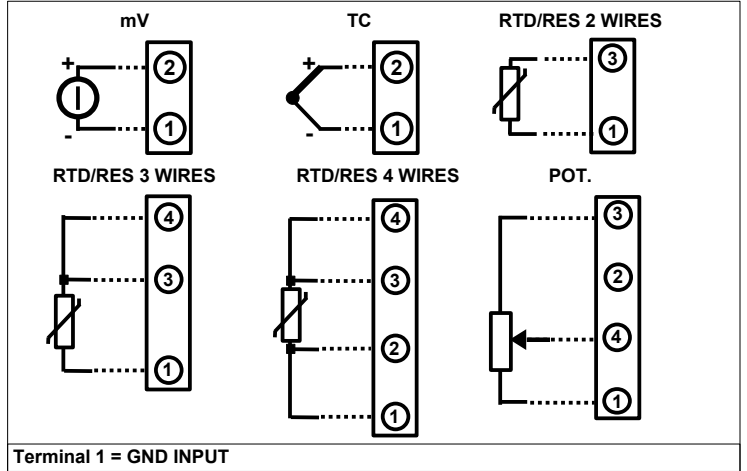

#### POWER SUPPLY CONNECTIONS

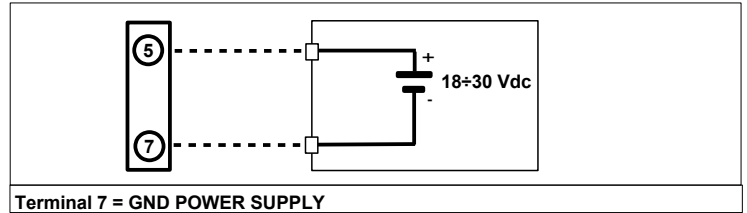

#### OUTPUT CONNECTIONS

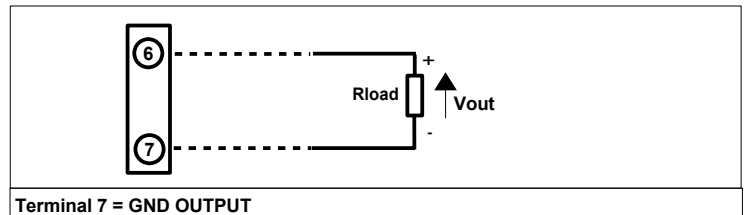

### ISOLATIONS STRUCTURE

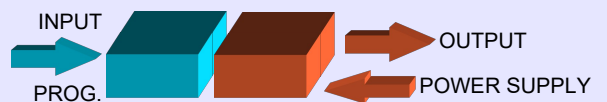

### MECHANICAL DIMENSIONS (mm)

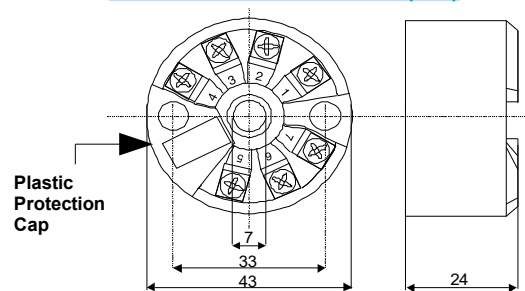

### HOW TO ORDER

The DAT1135 is provided as requested on the Customer's order. Refer to the section "Technical specification" to determine input and output ranges. The mounting kit for DIN rail is provided **only on request with code DIN RAIL**. In case of the configuration is not specified, the parameters must be set by the user.

#### ORDER CODE EXAMPLE:

